



## Features

- Low cost
- Dielectric strength: 1500 Vrms
- Fixed pin spacing allow easy PCB insertion
- Operating temperature: -55 to +105°C
- Custom Designs Available

## Application

- DC/DC, AC/DC line noise suppression
- Automotive Systems
- Communication System

## ► Dimensions & Configurations (Unit:mm)

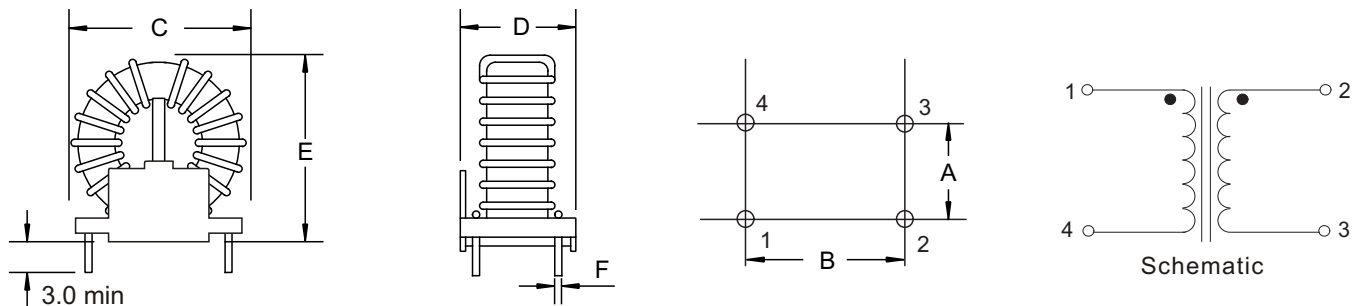

Type	A	B	C	D	E	F
CMT1730	17.78	30.48	44.45	25.40	44.70	1.20

## ► Electrical Characteristics For CMT1522 Series

Part Number	Inductance (min) [mH]	Rated Current [A]	DCR(max) [ $\Omega$ ]	Leakage Inductance [uH] Typical
CMT1730-3R0Y	3	15	0.009	20
CMT1730-5R0Y	5	12	0.035	50
CMT1730-120Y	12	6.8	0.098	95
CMT1730-150Y	15	4.2	0.132	150
CMT1730-220Y	22	3.2	0.352	280
CMT1730-330Y	33	2	0.730	300
CMT1730-560Y	56	1.8	1.000	550

1. Inductance is per winding, tested at 10KHz 0.1V
2. Leakage inductance is measured from pin 1 to pin 4 with pins 2 and 3 shorted
3. Electrical specifications at 25°C